

La Prima™ Sim Racing Clutch Manual

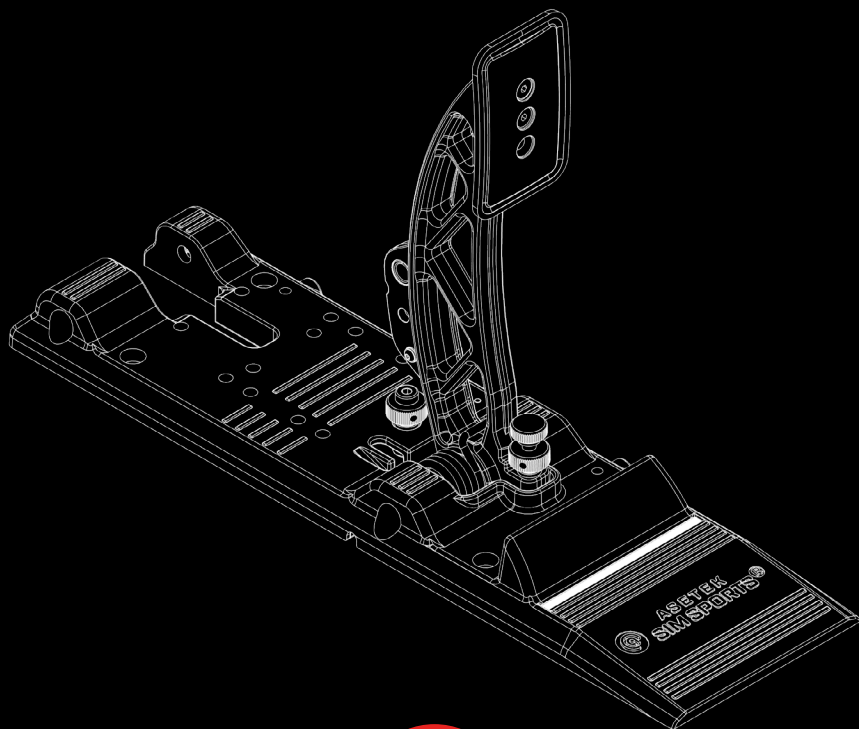

ASETEK
SIM SPORTS®

**Thank you for purchasing
the Asetek SimSports® La Prima™ Clutch.**

You have made an excellent choice!
We are sure the La Prima™ Clutch will help you take
your sim racing career to the next level. Whether
you are a beginner or an experienced racer, you will
now be able to reach ultimate immersion.

Prepare for the sensation of being in a real race car.

Table of contents

Foreword	4
About this document	4
Other Relevant Documents	5
Symbols Used	5
Copyright	5
1. Introduction	5
1.1 Box Contents	6
1.2 Videos	6
1.3 Manual version	6
1.4 Support & Contact	6
2. Product	7
2.1 Intended Use	7
2.2 Reasonably Foreseeable Unintended Use	7
2.3 Compatibility	8
2.4 General Specifications	8
3. Product Overview	8
4. Getting Started	9
4.1 Installing your Pedals	9
4.1.1 Tools Required	9
4.1.2 Optional Tools	9
4.1.3 Mounting to your Rig	9
4.2 Adjusting the Pedals	14
4.2.1. Pedal Face Plate Adjustments	15
4.2.2. Clutch Pedal Angle Adjustment	16
4.2.3 Clutch Travel Distance Adjustment	17
4.3 Start Racing!	17
5. RaceHub™ Adjustments	18
5.1 RaceHub™ Download	18
5.1.1 RaceHub™ Installation	18
5.1.2 RaceHub™ Updating	18
5.2 Introduction	18
5.3 Pedal Calibration	19
5.4 Deadzone Adjustments	20
5.5 Custom Pedal Mapping	21
6. Maintenance	22
6.1 Clutch Maintenance	22
6.2 Spare Parts	22
7. Troubleshooting	22
8. Safety	23
9. De-commissioning & Sustainability	24
9.1 Packaging	24
9.2 Product	24
9.3 Production	25
10. Declaration of Conformity	25



Foreword

About This Document

This manual is written for the end-user of the Asetek SimSports® La Prima™ Clutch and contains all information required to correctly and safely install, use and maintain the following models:

Model Name	P-C-1
Product Name	La Prima™ Clutch
Product Code	40-010-0000005

This manual was authored in English. All other languages are translations of the original document.

Please make sure that you have thoroughly read and understood all contents of this manual before installing, using, or performing maintenance on the pedals.

If anything in this manual is unclear, please contact Asetek SimSports® Support (available on www.asetek.com/simsports/support/).

Please note the serial number on your product before contacting the support. The serial number can be found on the bottom of the base plate and written here for your convenience:



Serial Number	
Asetek Denmark A/S Assensvej 2 9220 Aalborg East Denmark www.asetek.com	 ASETEK SIM SPORTS®

Other Relevant Documents

These documents may assist you in your quest for faster lap times:

- Mounting patterns
- Software
- DoC
- and other installation manuals can be found here:
www.asetek.com/simsports/knowledge-base/

Symbols Used

Make sure you pay attention to all warnings and symbols on the product and packaging.

Indicates that minor to moderate injuries may be sustained if the instruction is not followed correctly



This indicates that the product could be damaged if the instruction is not followed correctly



Copyright

The content of this manual is protected by copyright and other international intellectual property laws. The contents of this manual or any parts thereof may only be made public, copied, modified, reproduced, translated with express written permission from Asetek.

This manual or any parts thereof may only be published, transmitted, displayed, or made available to a third party with express written permission from Asetek SimSports®.

1. Introduction

Thank you for purchasing the Asetek SimSports® La Prima™ Clutch. We strongly encourage you to read through this manual thoroughly in its entirety. The La Prima™ clutch is a premium product made to fit each user. It has an excellent baseline adjustment out of the box, and we strongly encourage you to drive for 5+ hours with the baseline adjustments before changing anything. After that, your full immersion racing experience is unlocked when it is adjusted to your personal preference.



1.1 Box Contents

The box contains the following components and accessories:

- La Prima™ Clutch pedal
- Safety brief
- Warranty statement
- M6x5 set screw (x2)
- M6x20 bolt (x2)
- M6 Slot nut (x2)
- Washer (x2)
- M6 Hex nut (x2)
- Guiding pin (x2)

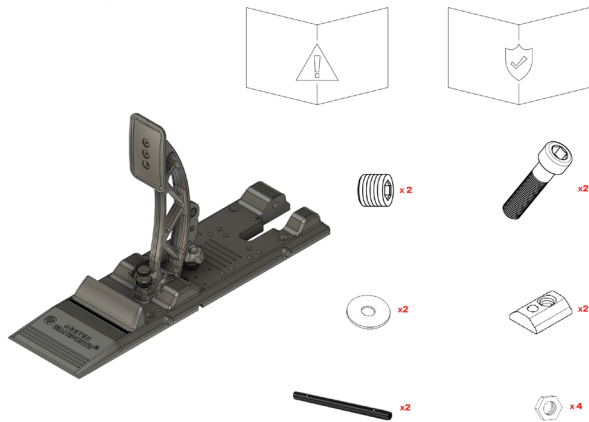

1.2 Videos

On the Asetek SimSports® YouTube channel

(<https://www.youtube.com/aseteksimsports>), you will be able to find tutorial videos which, in detail, demonstrates numerous ways the pedals can be set up and used. You will also find additional information about the development and ambition for the La Prima™ Clutch.

1.3 Manual version

This manual is version 1.0.

You will always be able to find the latest version of the manual at:

www.asetek.com/simsports/knowledge-base/

1.4 Support & Contact

Should you stumble upon further questions that are not covered in this manual or any of our detailed instruction videos, we encourage you to contact our friendly support staff at support@aseteksimsports.com

2. Product

2.1 Intended Use

Thank you for purchasing the Asetek SimSports® La Prima™ Clutch pedal; you have made an excellent choice! Asetek SimSports® La Prima™ pedals will bring you to the next level of your Sim Racing career. Whether you are a beginner or experienced gamer, you will feel the immersion of being in a real race car while racing the tracks across the globe in the virtual space.

The Asetek SimSports® La Prima™ Clutch pedal is designed to be used in competitive sim racing. The clutch can be directly connected to the Asetek SimSports® La Prima™ Brake & Throttle, with seamless and intuitive installation. The Asetek SimSports® La Prima™ Brake & Throttle pedals can be bought in our webshop or at an Asetek SimSports® authorized dealer. Do not use the pedals without mounting, as they may shift during use.

Note: The clutch cannot be used as a standalone product



The wheelbase is intended for indoor use only



Recommended ages 15 and above

2.2 Reasonably Foreseeable Unintended Use

The following is considered misuse and may void the warranty:

- Use of adaptors or extension sets for cables;
- Use of other cables than provided with the product;
- Use in an environment that varies from or exceeds the given environmental conditions;
- Use that varies from or exceeds the given operating conditions;
- Failure to comply with the instructions in this manual;
- Failure to eliminate faults, malfunctions, or defects of the product that impose safety risks;
- Unauthorized removal or modification of parts or safety devices of the product;
- Use of spare parts or accessories that Asetek SimSports® has not approved;
- Mounting and/or use of any parts in a vehicle;
- Adjusting pedal settings during operation;
- Operation in a flammable and/or explosive environment.
- Dropping the clutch (quickly and completely removing your foot) from the point of full actuation.
 - This would not be a use in a real car, and the pedals are not designed withstand these forces.



2.3 Compatibility

Platform(s)	PC (Windows 10, 11)
Games	Assetto Corsa Assetto Corsa Competizione DiRT Rally DiRT Rally 2.0 F1 Series iRacing Project Cars 2 rFactor 2 + many other games that accept direct input devices

2.4 General Specifications

Dimensions (D x W x H)	406 x 115 x 256 mm
Weight	1,4 kg
Materials	Pedals: Aluminum
Sensor Types	Hall sensor
Operating Temperatures	15°C to 35°C, room temperature

3. Product Overview

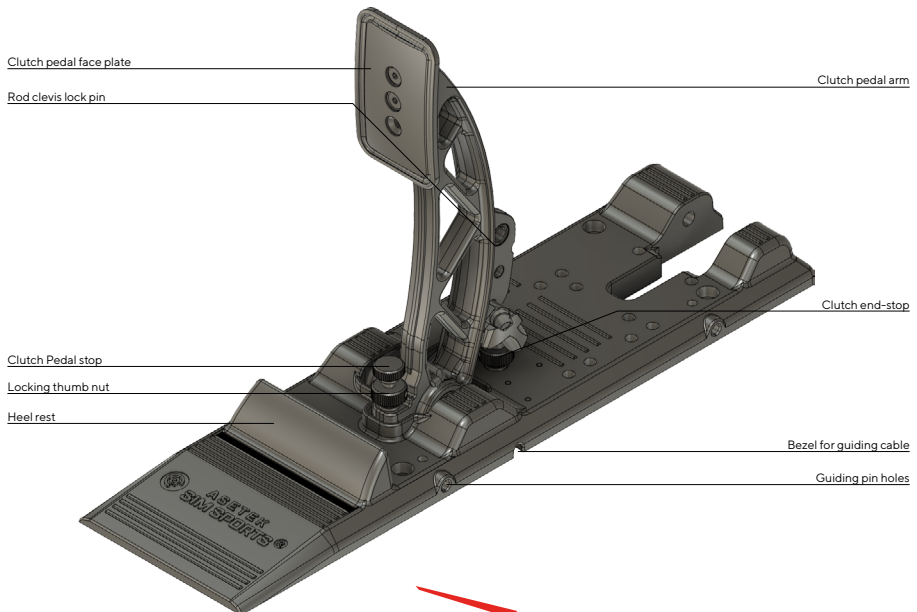

4. Getting Started

This section will teach you how to get your clutch set up and running. Later in the manual, you will learn much more about the fine-tuning and software.

4.1 Installing your Pedals

4.1.1 Tools Required

To mount the pedals in your cockpit, you will need the following tools:

- Allen key, 3 mm (not included)
- Allen key, 5 mm (not included)
- Key wrench (not included)

Note: Use the allen keys supplied with the Asetek SimSports® La Prima™ Brake & Throttle

4.1.2 Optional Tools

Depending on your rig and mounting preference, you may also need the following tools:

- Pencil or marker
- Screwdriver
- Power drill

4.1.3 Mounting to your Rig

The pedals are intended to be solely used while mounted to a sim racing rig.

The clutch has two (2) mounting holes in fixed positions. As such, all adjustments to the positioning of the base must be handled by your rig.

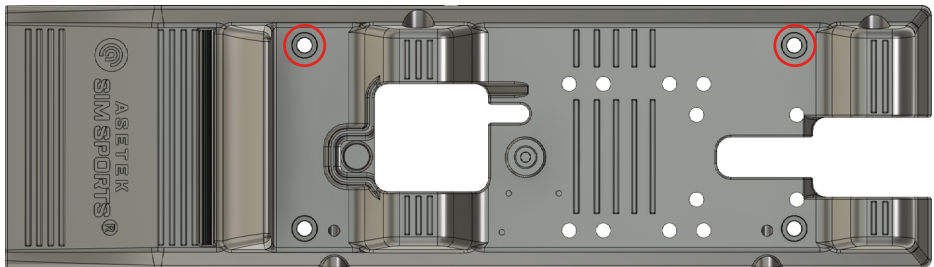

The baseplate is designed to be used with M6 screws, and holes in your rig should be with $\varnothing 6,4$ diameter. It is also compatible with the included M6 slot nuts.

The Asetek SimSports® La Prima™ pedals are designed to withstand an extreme amount of force. Therefore, it is paramount that you install them on a very rigid base. Ideal conditions are aluminum profile cockpits or a thick metal baseplate (as a minimum, we recommend: 3 mm, steel).

Mounting your pedals:

1. Carefully remove excess dust and debris from the installation location.
2. Dismount the La Prima™ Brake & Throttle
3. Unscrew the M6x5 set screws from the brake & throttle

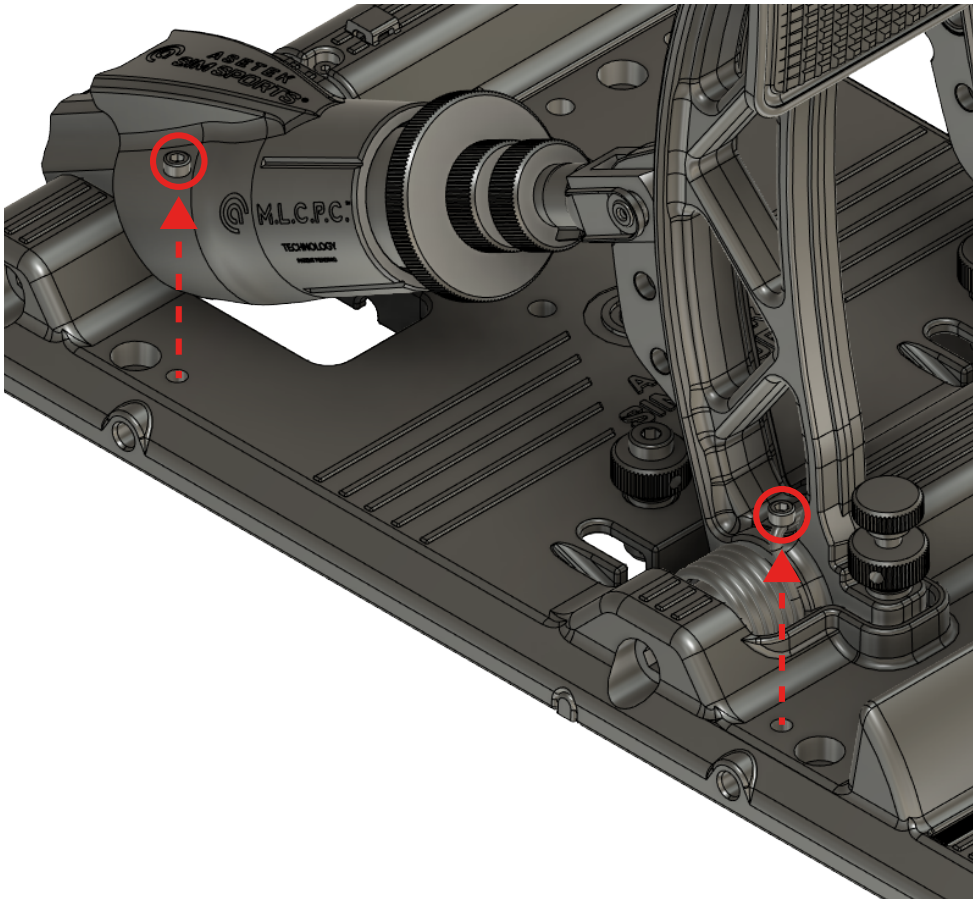

4. Insert the connection pins in the connection holes of the clutch

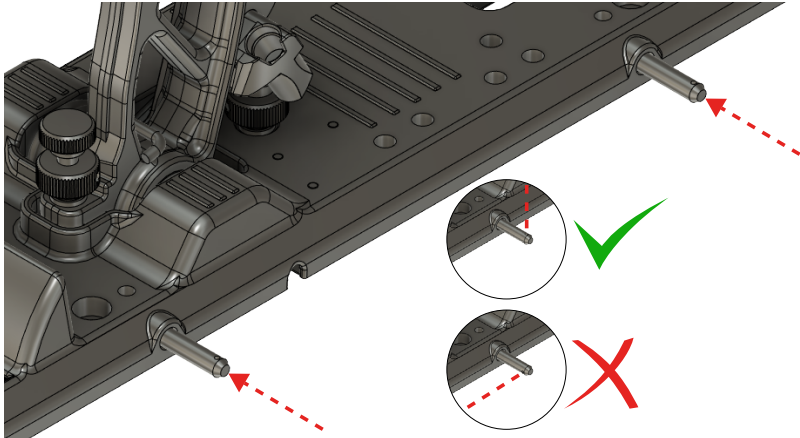

 **NOTICE**

Make sure that the holes in the guiding pins are pointing upwards.

5. Place the clutch next to your brake & throttle.
6. Use the guiding pins to align the clutch to the brake and throttle.
7. Insert the guiding pins of the clutch into the holes on the side of the brake & throttle.

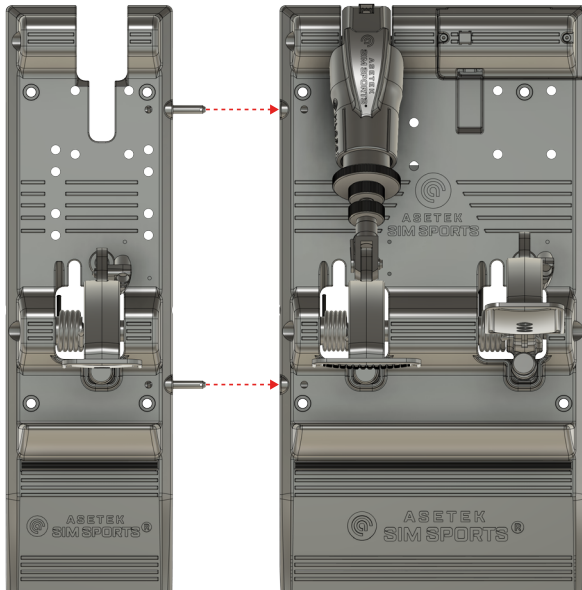

- Use the four (4) M6x5 set screws from above to secure the guiding pins in place.

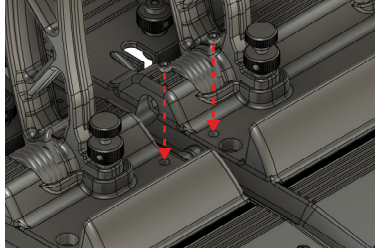

- Route the cable under the La Prima™ Brake & Throttle through the bezel and insert the cable to the La Prima™ Clutch

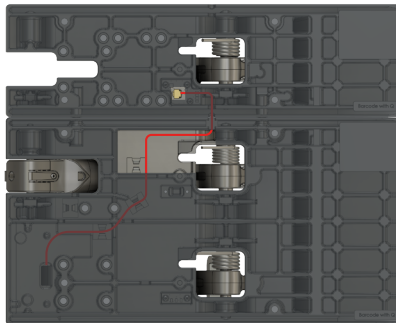

- Align the holes in the clutch to the two existing mounting holes in your sim racing cockpit, if available.

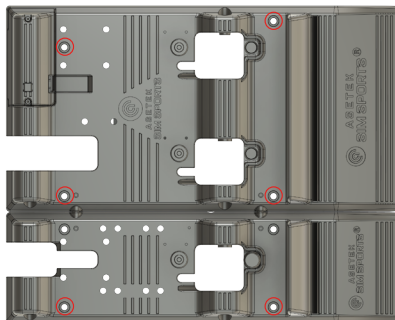

- Mount the clutch and brake & throttle to your sim racing rig.

If there are holes available:

- Mount the clutch to the existing holes using two (2) provided M6x20 bolts, two (2) washers, and two (2) hex nuts or two (2) M6 slot nuts (depending on your rig).



If there are no holes available or they do not line up, you can use the mounting schematics available here: www.asetek.com/simsports/product/la-prima-clutch-system/ or continue to step 13.

13. Mark the drilling locations.
14. Remove the pedal and drill two (2) $\text{\O}6.4$ mm holes.
15. Mount the pedal to the holes using the two (2) provided M6x20 bolts, two (2) washers, two (2) hex nuts or two (2) M6 slot nuts (depending on your rig).

Remember to attach the La Prima™ Clutch to the La Prima™ Brake & Throttle before mounting.

Congratulations. You have successfully mounted your Asetek SimSports® La Prima™ pedals to your rig. Enjoy the ride!



CAUTION

Do not use the pedals without mounting them according to the suggested surfaces at the start of 4.13

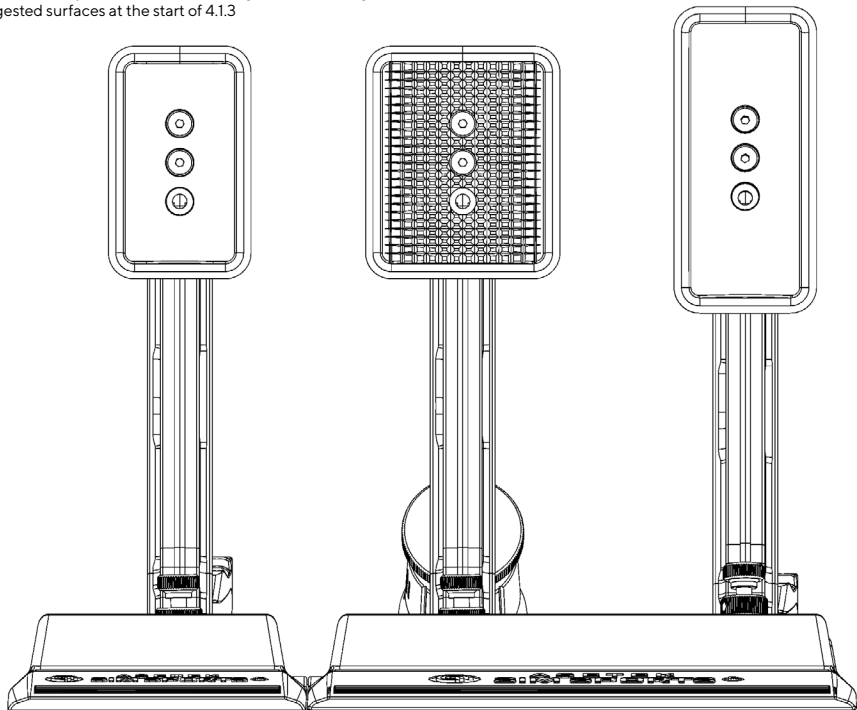

4.2 Adjusting the Pedals



CAUTION

Avoid eye contact with the lubrication grease and wash hands thoroughly after adjustment.

The Asetek SimSports® La Prima™ Clutch feature multiple mechanical adjustments, that can be made to increase the precision, performance, and experienced immersion. In this section we will teach you how to easily make these adjustments and further unleash your passion for sim racing.

The clutch is a crucial part when the race begins, and the drivers needs to get in front of the grid. The bite point is the exact moment where the clutch connects, and your race car moves forward.

It is essential to make sure you have the correct pedal angle in any racing style. Setting this correctly will allow you to use muscle-memory to your advantage, and make you go even faster around the track!

The clutch is set up in its default configuration (out of the box) to give you maximum immersion. In other words, they are set up to be focused on realism – like what you would find in a real race car. In combination with the La Prima™ Brake & Throttle, the La Prima™ Clutch is as default position, further forward from the brake to ensure that you will hit the brake pedal as the first thing in an emergency on track.

The setup of the La Prima™ pedals (clutch and brake & throttle) is how it works in a real race car. We recommend you drive for several hours first and try to adapt. In a real race car, where you often have different drivers in the car (as well as in many endurance sim races), the pedals are adjusted like the above, and there is no opportunity to change that specifically to any driver.

If you prefer settings otherwise, the pedal angle can easily be adjusted, due to the easily adjustable toolless system.

4.2.1 Pedal Face Plate Adjustments

NOTICE

Do not use a power drill, as this may damage the screws.

La Prima™ pedal face plates can be adjusted along the X and Y-axis. It will allow the pedals to accommodate a variety of different shoe sizes and increase performance and comfort for anyone using the pedals.

To adjust the position, follow these easy steps:

1. Remove the screws with an allen key from the pedal face plates
2. Align the holes on the pedal arm with the desired holes on the pedal face plate.

NOTICE

Only use the holes marked green for mounting.

3. Insert and fasten the screws with an allen key.

Note: The screws can bite hard, so be careful not to overtighten or have the tool slip.
Recommended torque: 2nm

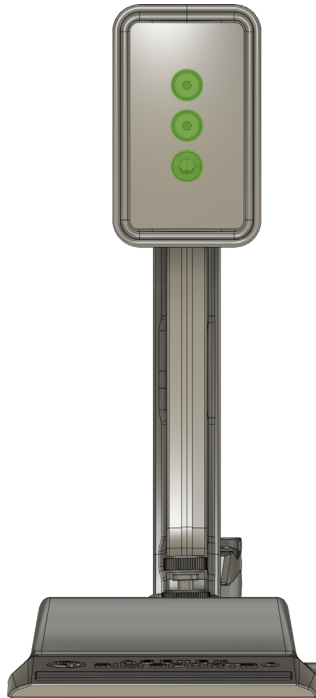

4.2.2 Clutch Pedal Angle Adjustment

To make sure your pedals are set up just the way you like them, the La Prima™ Clutch pedal offer the possibility of adjusting the angle of the pedal. The adjustment is a simple process. Simply follow the instructions below:

1. You can adjust the pedal stops on the clutch pedal by loosening the locking thumbnut

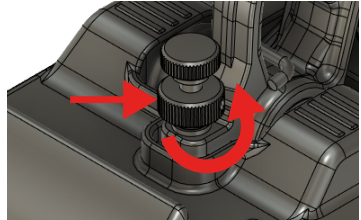

3. Push the pedal slightly forward, and rotate the thumbscrew (Clockwise to move the pedal forwards, counterclockwise to move the pedal backwards)

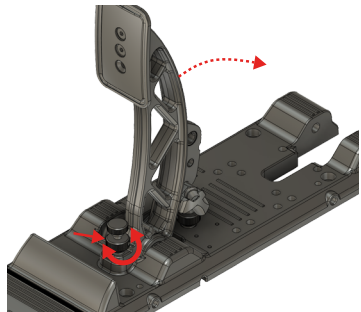

4. Once you have achieved your desired position, tighten the locking thumbnut

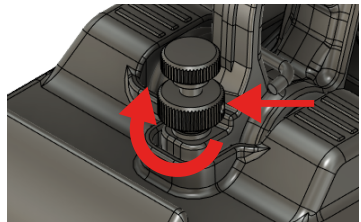

5. Recalibrate your clutch in RaceHub™ (see section 5.3 Pedal Calibration)

We suggest that you have the brake pedal arm tilted a bit more forward than the throttle and clutch, as in a real car. Imagine driving a race car and things go wrong and you are losing your car, you would rather press the brake than the throttle to avoid a potential crash.

4.2.3 Clutch Travel Distance Adjustment

The clutch can have its travel distance adjusted. This allows you to set a new pedal stop of your clutch pedal – essentially reducing the distance of activation and the feeling of resistance as you move through less of the available spring distance.

The process can be done in four (4) simple steps:

1. Loosen the thumbnut on the pedal stop, behind the pedal arm, by rotating it counterclockwise.

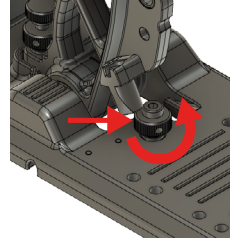

2. Use an allen key to adjust the height of the allen screw.

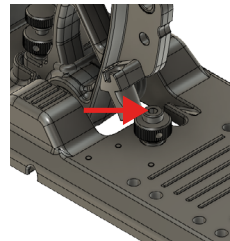

3. Re-tighten the thumbnut by rotating it clockwise.

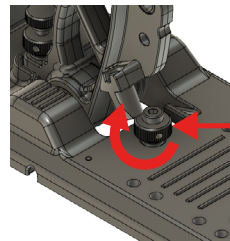

4. Recalibrate your clutch in RaceHub™.

4.3 Start Racing!

Your pedals are ready for racing – even without adjusting them in the software. There are several adjustment options – but before changing anything, try to drive for several hours and adapt to the feeling of a real race car.

Assign the pedals in your favorite simulator game and you are ready to go.

5. RaceHub™ Adjustments

All Asetek SimSports® products come with an extremely powerful yet easy-to-use piece of software that we have developed from the ground up. It is called RaceHub™ and will take care of your every need. RaceHub™ unlocks things you would not dare to dream and is continuously updated.

5.1 RaceHub™ Download

RaceHub™ is available for download, in its newest version, on our website (www.asetek.com/simsports/racehub/).

5.1.1 RaceHub™ Installation

After completing the download from our website, double-click the downloaded file to initiate the installation. Follow the on-screen instructions and install them in your desired directory. Once installed, open RaceHub™ using the shortcut on your desktop or in your programs folder.

5.1.2 RaceHub™ Updating

RaceHub™ will automatically notify you if there are available updates. If you want to double-check, please go to www.asetek.com/simsports/racehub and download the newest version.

RaceHub™ has a built-in feature that allows you to update the firmware on your devices automatically.

5.2 Introduction

Asetek SimSports® RaceHub™ allows you to make a plethora of adjustments to your Asetek SimSports® products. On the La Prima™ pedals, it will allow you to adjust pedal maps, calibrate your pedals, and much more.

Everything is available in a highly user-friendly interface that allows for quick and easy customization that not only gives you complete control but does it in a manner where you are constantly in focus – teaching you everything you need to know to become a power user and expert sim racer.

The settings that you choose in RaceHub™ will be applied to all the supported games found in section 2.3, “Compatibility”—ensuring maximum performance and precision!

5.3 Pedal Calibration

To ensure your pedals are as precise as they can be, you should run the pedal calibration wizard in RaceHub™. It is a quick and straightforward process that takes you through a series of activations that calibrate your pedals.

1. Navigate to the pane in RaceHub™ called Calibration
2. Push the calibrate button

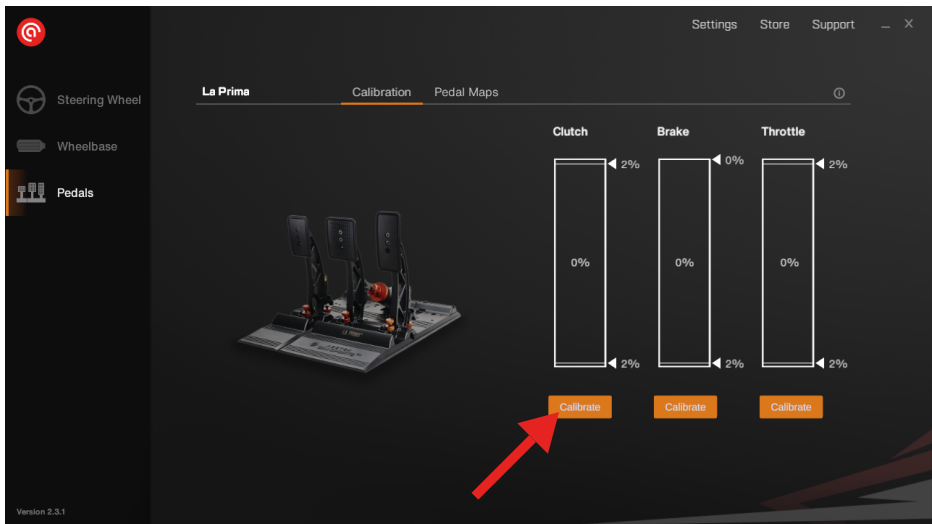

3. Follow the on screen instructions
4. Done! Your calibration will carry over into all the supported games.

Once your pedals are calibrated, only a few unique scenarios will cause a need for recalibration:

- a. If so desired, you have adjusted mechanical stop of your clutch pedal.
- b. If so desired, you have adjusted the static angle of your clutch.

5.4 Deadzone Adjustments

In RaceHub™, you will be able to set both top and bottom deadzones on all your pedals.

A bottom deadzone allows you to slightly activate your pedal without engaging the clutch. For example, if you rest your foot on the pedal. A top deadzone allows you to modify the point of full activation. In the case of a clutch pedal, this would allow you to reach 100% clutch before your clutch pedal reaches full activation and the mechanical pedal stop. This preference is individual and generally done by a race engineer before the car goes on track. RaceHub™ allows you to fully customize it and we strongly encourage you to do it as well.

The top and bottom deadzones can be adjusted using these sliders marked here:

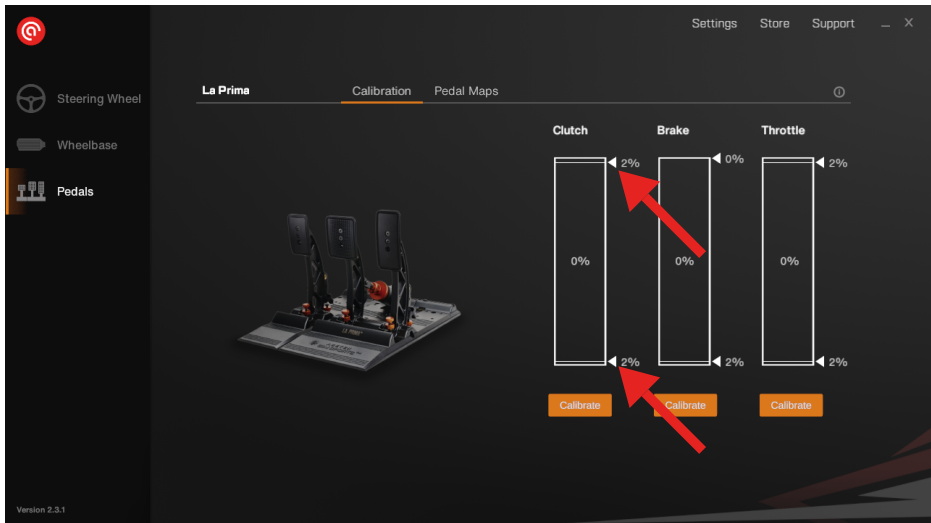

We suggest the following settings for deadzone when using the Asetek SimSports® La Prima™ pedals, which is how it is calibrated from our factory.

Clutch:

- Top: 2%
- Bottom: 2%

5.5 Custom Pedal Mapping

One of the great features of RaceHub™ is the ability to map the curves of your pedals precisely to your liking. In most racing simulator pedals, you will find a 1:1 relation between the amount pressed on the pedal and the response in-game. This is not how things work in real racing – so why should it be this way in your sim rig? The answer is, it should not, and our pedal maps help you avoid just that.

We have made a few preset curves that mimic typical scenarios, but RaceHub™ also allows complete customization of your pedal curves. Click, drag and drop – it is that simple!



Similarly, you can adjust your curves based on your driving conditions—all in search of ultimate performance.



Please note that RaceHub™ custom pedal maps work best when they are used exclusively and without the use of potential in-game settings. If your preferred simulator game offers a pedal mapping feature, we highly suggest you leave it as linear and instead use the functionality in RaceHub™.

6. Maintenance

Owning a set of La Prima™ pedals means a minimum of maintenance needed. However, we do have a few suggestions that will help you keep your pedals feeling supreme.

6.1 Clutch Maintenance

We suggest you clean the clutch with regular intervals (6 months) with a soft, dry, clean cloth.

If unwanted rubbing sounds occur, we suggest using PTFE Dry Spray.

NOTICE

Do not use water or cleaning agents to clean the product.

6.2 Spare Parts

We strongly advise you only use original Asetek SimSports® spare parts. Failure to do so will void your warranty.

If you have questions, or do not know if you have an original part, please refer to www.asetek.com/simsports/ or consult the Asetek SimSports® support via: www.asetek.com/simsports/support

7. Troubleshooting

Sometimes unforeseen issues occur. But do not worry, we are here to help.

If you are having issues we suggest consulting the FAQ on www.asetek.com/simsports/knowledge-base/

If you are not able to find a solution on the FAQ please consult our friendly and knowledgeable support staff via www.asetek.com/simsports/support or through our social channels.

8. Safety

- The device must not be exposed to rain or humidity to avoid the risk of fire and electric shock.
- We strongly advise you not to drive a vehicle immediately after racing simulation games.
- This product is not intended for children under the age of 15 years.
- Contains small pieces. Danger of swallowing!
- Extended periods of gaming may cause health risks. Take a break of 5 minutes every 20 minutes, and do not play for more than 2 hours per day.
- Keep hands, fingers, hair, clothing, and jewelry away from the product when in use.
- Only one person may use the product at any given time. Keep other persons away from the product when in use.
- Keep the product and the power cord away from children and pets.
- This product contains components that the user cannot repair. Opening parts of the product may compromise the safe use of the product and will void the warranty.
- Do not disassemble this product beyond what is described in the product manual.
- Avoid eye contact with the lubrication grease and wash hands thoroughly after adjustment.
- Make sure the mounting of the pedal set and all parts are secured tightly before use.
- Check frequently that the pedals are mounted properly
- Be aware that the rod clevis has sharp edges

9. De-commissioning & Sustainability

At Asetek we are fiercely committed to making the world a sustainable place. You can read more about Asetek’s sustainability efforts, including our sustainability reports, here: www.asetek.com/company/sustainability

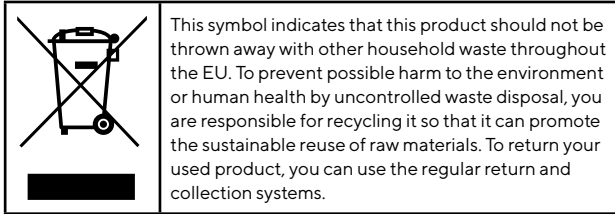

9.1 Packaging

All packaging is made out of paper and cardboard. All our cardboard and paper products are labeled with the FSC mark, ensuring maximum reusability and that the forests are sustainably forested. Furthermore, we regularly check our vendors to make sure they are upholding their commitments.

About FSC: www.fsc.org/en/fsc-labels

If you need to dispose of your packaging, please use the appropriate paper waste stream in your country, to dispose of the packaging. Naturally, we hope you want to keep it around – we are quite proud of it.

9.2 Product

Asetek SimSports® is committed to making products that will last. However, we also know that sometimes things break, and that should not result in a scrap and forget, producing even more e-waste to our planet. That is why we are dedicated to supporting you and all other users with spare parts where possible, and in case of parts of the product defuncting, we offer return shipping of the part along with a new service part. We will then make sure the original part is de-commissioned in an environmentally sound manner.

If you feel uncertain about how to recycle any Asetek SimSports® product, we suggest getting in touch with our dedicated customer support team, who will happily help you. Contact them here: www.asetek.com/simsports/support

9.3 Production

The Asetek SimSports® La Prima™ Pedals are produced using primarily aluminum die-casting and forging techniques. As such, any waste aluminum is re-used, minimizing waste.

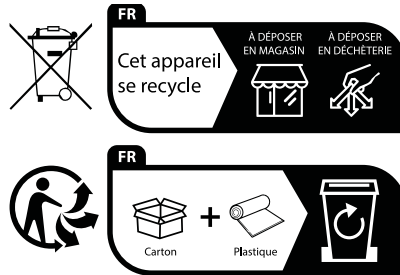

Points de collecte sur www.quefairedemesdechets.fr
Privilégiez la réparation ou le don de votre appareil !

10. Declaration of Conformity

We, Asetek, as manufacturer, declare that the La Prima™ products from the brand Asetek, produced in Denmark are tested according to all relevant CE standards/ regulations and passed all tests.

The complete Declaration of Conformity can be found and downloaded via www.asetek.com/simsports/product/la-prima-clutch-system/

The screenshot shows the Asetek website product page for the La Prima™ Clutch System. The page includes a navigation bar with 'Liquid Cooling', 'SimSports', and 'Company'. The main content area features a large image of the clutch pedal assembly, a price tag of €126,04 (excluding VAT), and a detailed description of the product's quality and features. A red arrow points to the 'Downloads' link in the bottom navigation bar, which is labeled 'Out of stock'.

Overview

Tech Specs

Compatibility

Downloads



*LA PRIMA*TM